

Three Messages - One Simple Sign

Triplesign

The Triplesign gives you the flexibility to display three messages in one sign. Choose to rotate the prisms continuously, or change the message only when the need arises – it's up to you!



Simple Installation

The Triplesign's intuitive plug-and-play installation process helps you get your sign installed and running in just an hour or two.

Low Power Consumption

1 watt/hour means a minimal cost to power the sign.

Works in All Environments

Rust-resistant components, powerful motors, and an optional Polar Guard system with heating elements allow the Triplesign to function anywhere, from marine environments to the harshest winter conditions.

Off-Grid, On-Message

With the optional battery and solar panel, the Triplesign is equipped to operate in even the most remote locations. It is also immune to power outages, as there is no power required to continue to display the selected message.

The messaging you need, and nothing you don't

No LED panels to change, no complicated operating systems. Just a simple, elegant sign that dependably does the job right - all day, every day.

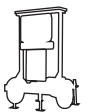

HOW IT WORKS



The display of the Triplesign is composed of rotating 3-sided prisms controlled by a chain-free, non-binding motor. At the push of a button or the click of a mouse, you can change which face of the sign is displayed to oncoming traffic.

You can also have the prisms rotate continuously, either back and forth between two messages, or looping through all three.

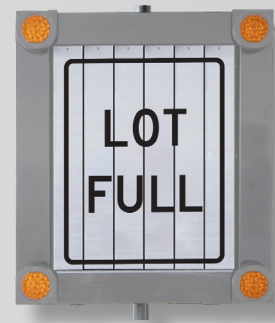

Recognized by Vehicle Cameras

Traffic Sign Recognition System (TSR) compliant - unlike many LED signs, the Triplesign's messages are always recognized by Advanced Driver Assistance Systems (ADAS).

Command & Control

Change your sign either locally or access your Triplesign wirelessly (4G or Wi-Fi) through a built-in web interface, or connect directly via a wired connection.

Sign can be configured to automatically change via built-in schedule.

Power

An optional battery system and properly sized solar panel gives the Triplesign the ability to operate in even the most remote locations. You can also connect directly to city power.

Either way, the Triplesign consumes less power in an entire day than the average household consumes in just a few minutes.

Maintenance

With no bulbs to replace, minimal wiring, and simple construction, the Triplesign rarely requires more than regular visual inspections and occasional cleaning of the display faces.

After two full decades of use, it is recommended to replace the mechanical components, which takes less than an hour to complete.

Patented Chainless System

Non-binding mechanism with no chains means that individual panels on the sign never get off-track or out of sync.

Green

The Triplesign itself, when paired with the solar panel, is also 100% self-sufficient, and because it has few moving parts and extremely durable construction, can last up to 4 times longer than LED variable message signs (VMS).

The Triplesign is manufactured in a 100% self-sufficient facility complete with solar power, geothermal heating, and an all-electric fleet of vehicles.

US LARGE

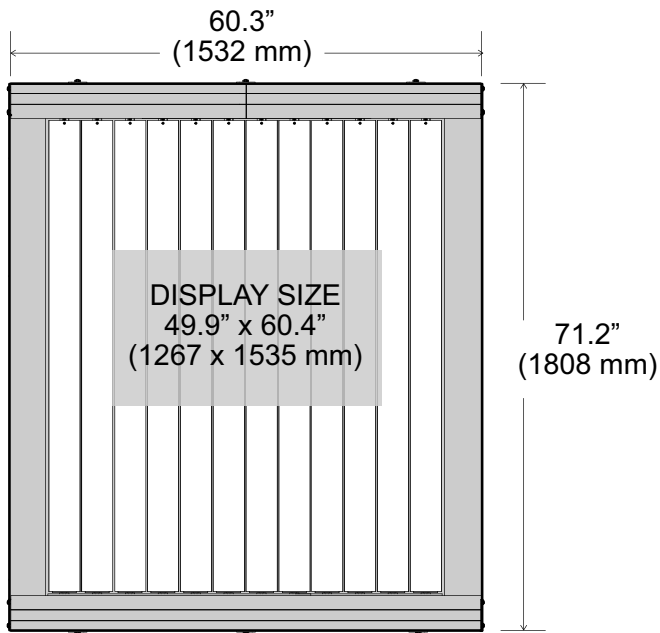

US SMALL

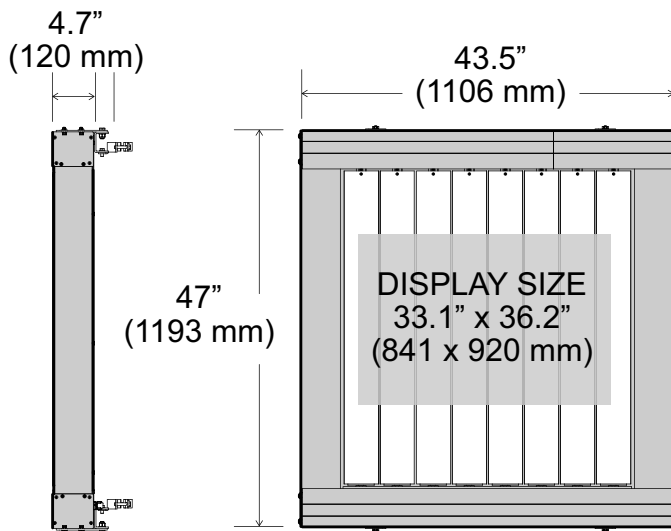

SAVES OVER \$10,000

in electricity and board
maintenance over the sign's
lifetime vs. an LED-driven VMS sign.

TripleSign Use Cases:

- Unattended Railroad Crossings
- Roads with Dynamic Speed Limits
- Road Construction
- Animal Crossing Zones
- School Zones
- Parking Lots
- Road Closures
- HOV Lanes Open/Closed
- Directing Event Traffic
- Weigh Stations
- Flood Zones
- Alternate Routes
- Loading Zones
- High Wind Areas

Specifications

	US Small	US Large
Display Size	33.1" x 36.2" (841 mm x 920 mm)	49.9" x 60.4 (1267 mm x 1535 mm)
Cabinet Size	43.5" x 47" (1106 mm x 1193 mm)	60.3" x 71.2" (1532 mm x 1808 mm)
Depth	4.7" (120mm)	4.7" (120mm)
Prisms	8	12
Weight	92.6 lbs. (42 kg)	121.3 lbs. (55 kg)
Weight with batteries/solar assembled	174 lbs. (79 kg)	213 lbs. (97 kg)
Ingress Rating	IP56	IP56
Power Consumption	1.1 watt/hour	1.1 watt/hour
Autonomy (Solar w/ no sun)	22.5 days @ 75 ° F	25 days @ 75 ° F
Warranty	3 years	3 years

Options



- Amber flashers (sets of 2)
- Polar Guard heating system
- Power:
 - A/C
 - Solar with Battery
- Command/Control:
 - 4G Wireless connection
 - Ethernet
 - RS-485
 - Wi-Fi
 - Local



Learn more at:
StreetDynamics.com/triplesign

StreetDynamics.com
1-800-782-5537

STALKER
STREET DYNAMICS

applied concepts, inc.

855 East Collins Blvd. ■ Richardson, Texas 75081
 972.398.3780 ■ Fax 972.398.3781

006-0083-00 Rev C

Copyright © 2023 Applied Concepts, Inc. All Rights Reserved.

LIVES
 depend
 on what we
DO